

Enable 3D View

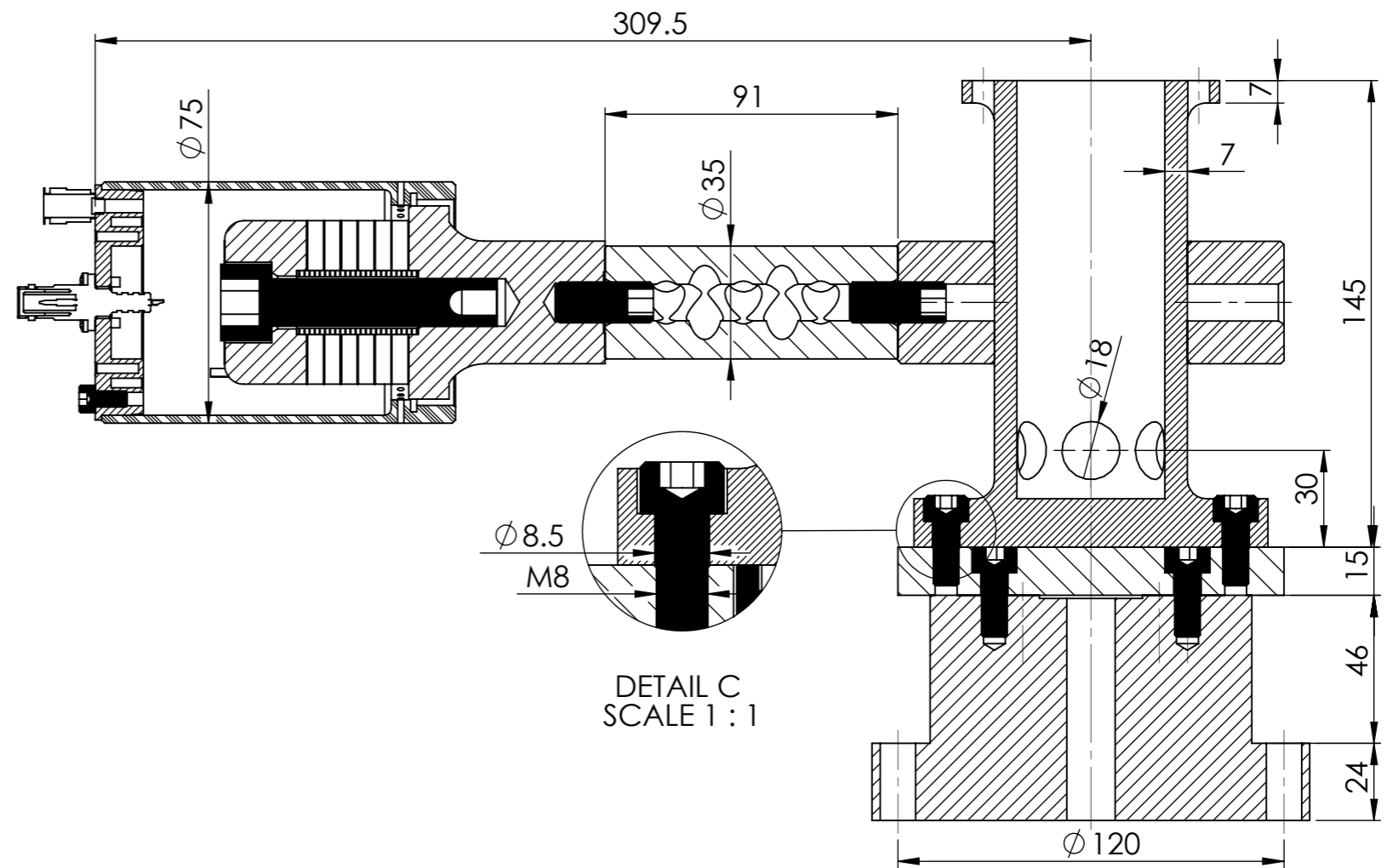

SECTION A-A

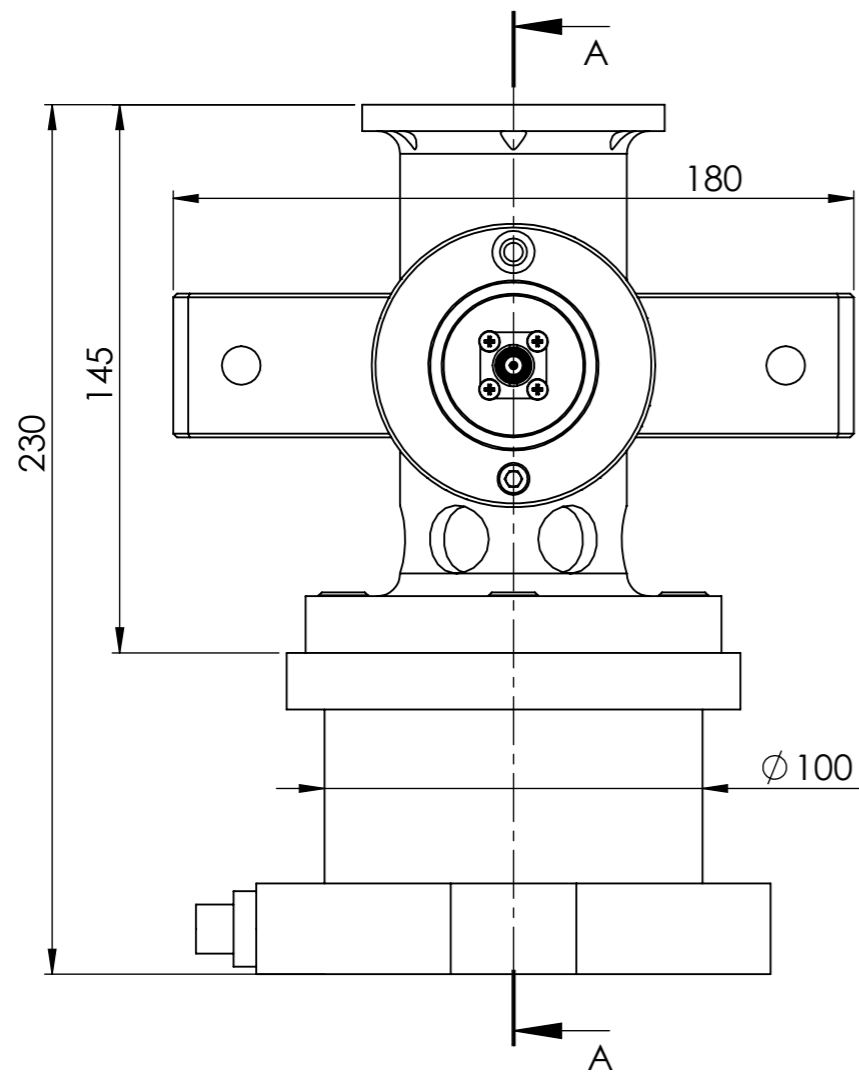
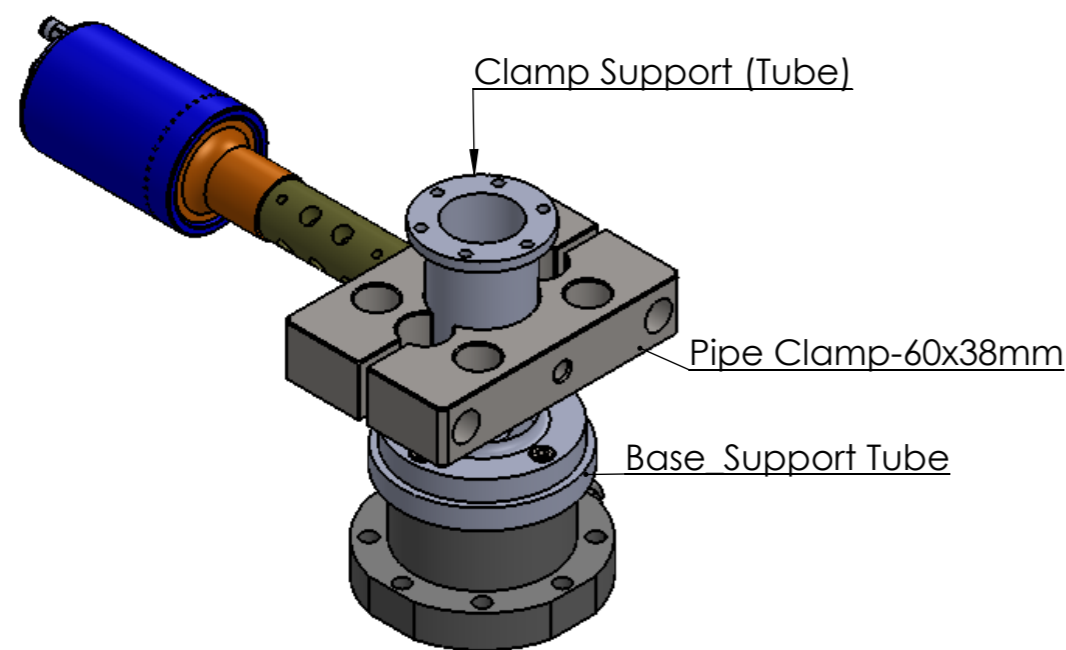

N8 Ra 1,6

general angle 0,3...0,5

PROJECT DIRECTOR M.Prokic	DATE 08.04.2013	DEBUR AND BREAK SHARP EDGES	DO NOT SCALE DRAWING	REVISION		
drew H. Puga	DATE MODIFY 14.12.2013		<b>MPI-ULTRASONICS</b> MARAIS 36 2400 Le Locle Switzerland e-mail : mpi@mpi-ultrasonics.com phone +41 (0) 32 9314045			
MATERIAL:						
<b>General tolerance SN 258440</b>						
dimension nominale (mm)	>3 ...6	>6 ...30	>30 ...120	>120 ...400	>400 ...1000	>1000 ...2000
Ecart (mm)	± 0.05	± 0.1	± 0.15	± 0.2	± 0.3	± 0.5
			SCALE: 1:1	SHEET 1 OF 1	A3	

Drilling US